

- USE COURSE WOOD WORKING TOOLS FOR CUTTING AND DRILLING.
- ALLOW FOR THERMAL EXPANSION AND SHRINKAGE BY LEAVING GAPS BETWEEN END OF BOARDS.
- USE PLATED SCREWS TO JOIN BOARD TO STAKE.
- DO NOT SCREW BOTH BOARDS TOGETHER.

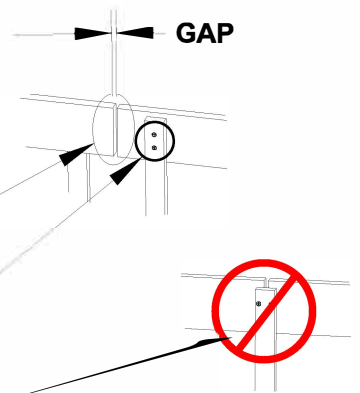

AVAILABLE ACCESSORIES FOR EPIC EDGE COMPOSITE HEADER BOARD PRODUCTS		
ACCESSORY DESCRIPTION AND COLOR	ACTUAL DIMENSION	PRODUCT NUMBER
12 BENDA BOARD PLASTIC STAKE / CARMEL BROWN	.67 in x 11.75 in x 1.38 in 1.7cm x 29.84cm x 3.5cm	100036740
STEEL J STAKE 1x4 / REDWOOD	1.35 in x 12.75 in x 1.28 in 3.42cm x 32.38cm x 3.25cm	100036741
12 PRE-DRILLED STAKE / TEAK BROWN	.67 in x 11.75 in x 1.38 in 1.7cm x 29.84cm x 3.5cm	100036742
18 PRE-DRILLED STAKE / TEAK BROWN	.67 in x 17.75 in x 1.38 in 1.7cm x 29.84cm x 3.5cm	100046315
#6 GALVANIZED SCREWS	1-1/4 in 3.05cm	200079367

PRODUCT NUMBER	NOMINAL DESCRIPTION	COLOR	ACTUAL DIMENSION D x H x L	MINIMUM RADIUS	GAP	MAXIMUM CROWN H / L	RECOMMENDED ACCESSORIES
100041851	4 X 20	CARMEL BROWN	.55 in x 3.35 in x 20 ft 1.40cm x 8.5cm x 6.09m	36"	1/8"	19 in / 20 ft	ALL LISTED ON NEXT CHART
100036756	6 X 20		.55 in x 5.35 in x 20 ft 1.40cm x 13.58cm x 6.09m			9 in / 20 ft	

EPIC EDGE COMPOSITE HEADER BOARD DETAIL # 210

MADE IN USA by EPIC PLASTICS
104 E. TURNER RD, LODI CA 95240
www.epicplastics.com

EPIC EDGE BOARD IS INTENDED FOR NON-STRUCTURAL USE ONLY